



ASPARI

paving the way forward



Međunarodni seminar
ASFALJNI KOLNICE 2018

Internat. seminar ASPHALT
PAVEMENTS 2018

Opatija, 12.–13. 04. 2018

The Dutch case

*The impact of changes in public procurement
on the health of the Dutch paving industry*

Prof André Dorée

UNIVERSITY TWENTE

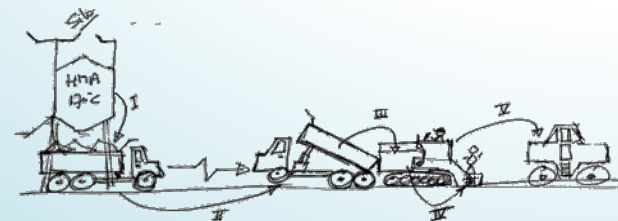

UNIVERSITY TWENTE

www.ASPARi.nl

The Croatian case

- years of investments and industry expansion
- **4.2 mio ton (2008) dropped to 2.2 ton(2016)**
- financial burden strangulates the industry
 - currently mainly maintenance jobs
 - 4 year contracts; smaller projects
- competition **dominated by low bid**
- expertise concentrated in *Croatian Roads*
- industry feels squeezed



Međunarodni seminar
ASFALNI KOLNICI 2018

Internat. seminar ASPHALT
PAVEMENTS 2018

Opatija, 12.–13. 04. 2018



some stats



Međunarodni seminar
ASFALJNI KOLNICE 2018

Internat. seminar ASPHALT
PAVEMENTS 2018

Opatija, 12.–13. 04. 2018

In 2016	Croatia	Netherlands
Land area (sq km)	56000	33900
GDP (billion euro)	56	772
GDP/capita (keuro)	13.2	46.0
Population (mio)	4.5	16.8
Tonnage annual	2.2 mio	8.2 mio
Companies		
Production only	1	0
Production & laying	52	17
Laying only	10	15
Recycling HMA (%)	50	71
Production sites		
Static	53	37
Mobile	2	0
Fit for recycling	14	37

The best driving experiences in the world

Data from 50 million drivers. Country score based on traffic, road infrastructure, accident rate, hazards, and access to driver resources



Source: Waze

some stats

In 2016	Croatia	Netherlands
Land area (sq km)	56000	33900
GDP (billion euro)	56	772
GDP/capita (keuro)	13.2	46.0
Population (mio)	4.5	16.8
Tonnage annual	2.2 mio	8.2 mio
Companies		
Production only	1	0
Production & laying	52	17
Laying only	10	15
Recycling HMA (%)	50	71
Production sites		
Static	53	37
Mobile	2	0
Fit for recycling	14	37



Međunarodni seminar
ASFALJNI KOLNICI 2018

Internat. seminar ASPHALT
PAVEMENTS 2018

Opatija, 12.–13. 04. 2018

The best driving
experiences in
Data from 50 million drivers
road infrastructure
to driver res

my research perspective:

impact of procurement →
industry change &
incentive to innovate

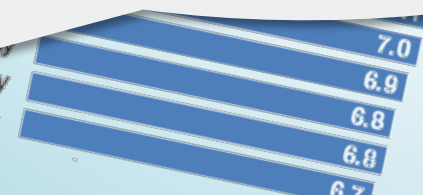

today

- The Dutch case
 - intro **ASPARi** (*asphalt paving research & innovation*)
 - explaining the transition
- procurement & the logic of change
- where to go from now
- *lessons for the Croatian case ?*



Međunarodni seminar
ASFALJNI KOLNICI 2018

Internat. seminar ASPHALT
PAVEMENTS 2018

Opatija, 12.–13. 04. 2018





ASPARI is ... (asphalt paving research & innovation)

- network of
 - 11 contractors (> 85% NL industry)
 - researchers University Twente
- to enhance capabilities & performance of the road construction industry



Međunarodni seminar
ASFALNI KOLNICI 2018

Internat. seminar ASPHALT
PAVEMENTS 2018

Opatija, 12.–13. 04. 2018

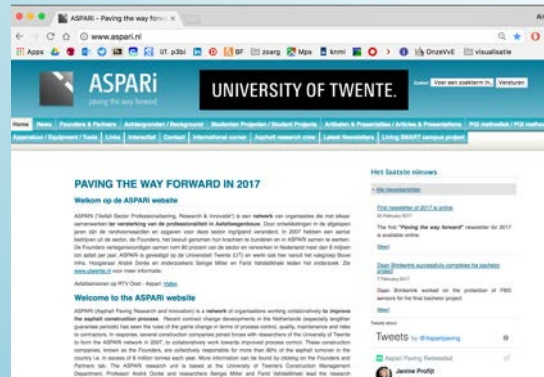

ASPARi is...



Međunarodni seminar
ASFALJNI KOLNICE 2018

Internat. seminar ASPHALT
PAVEMENTS 2018

Opatija, 12.–13. 04. 2018

deploying & developing new technologies
developing new practices & operational strategies

data driven & operator centred approach
focus quality and learning
developing analytics & metrics
aligning/demanding technology of suppliers
promoting the industry amongst students
ongoing for 10 plus years; continuity

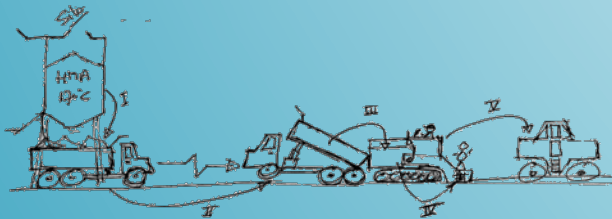

Data driven

For each spot on the road:

- georeferenced
- time & temperature of laying
- cooling history surface & core (plus weather)
- compaction curve
- compaction history (registers each roller pass, time, temperature)

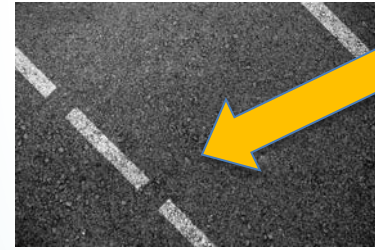

Međunarodni seminar
ASFALNI KOLNICI 2018

Internat. seminar ASPHALT
PAVEMENTS 2018

Opatija, 12.–13. 04. 2018

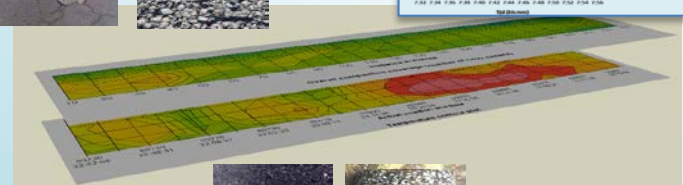
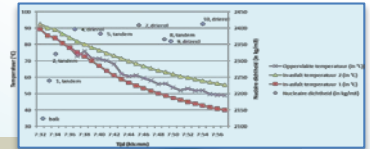
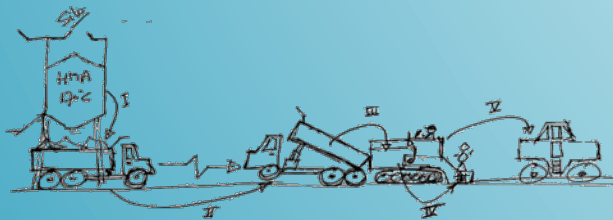

Deploying modern technologies



Međunarodni seminar
ASFALJNI KOLNICI 2018

Internat. seminar ASPHALT
PAVEMENTS 2018

Opatija, 12.–13. 04. 2018

Developing a real-time process control system for asphalt paving and compaction

Denis Makarov, PDEng, 2015-12-16

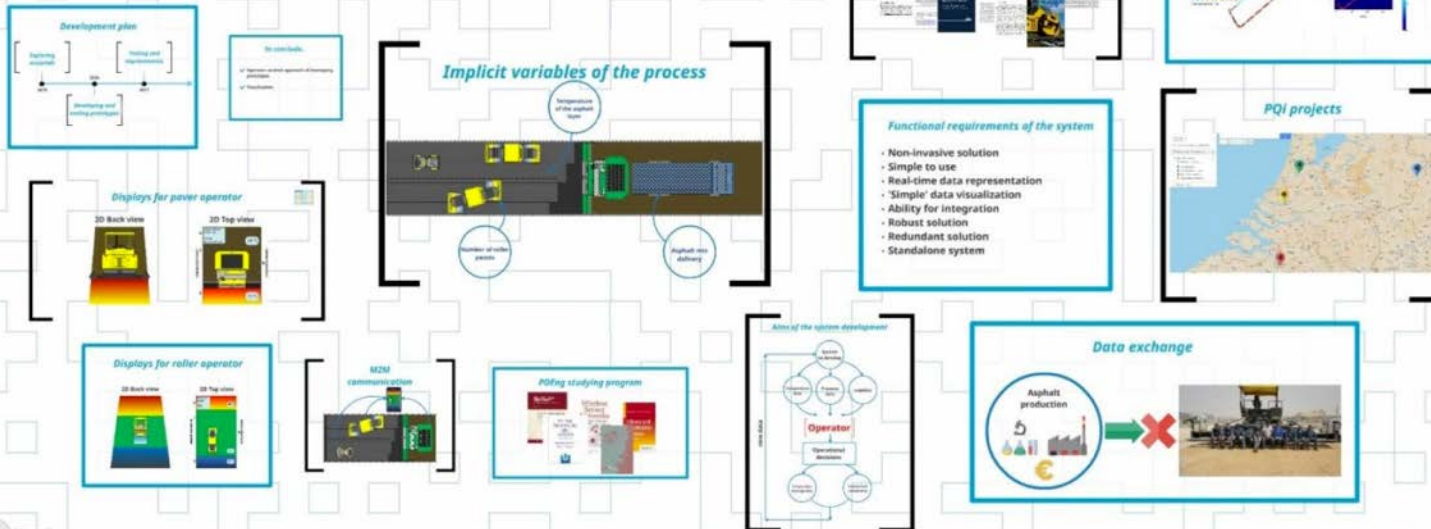



The heart of the matter....



Međunarodni seminar
ASFALJNI KOLNICI 2018

Internat. seminar ASPHALT
PAVEMENTS 2018

Opatija, 12.–13. 04. 2018

Significant **changes in contract types** and subsequent competition formats

..... pushed the NL road builders to **rethink the essence of their business models**



UNIVERSITY TWENTE

www.ASPARi.nl

Construction Industry NL



Međunarodni seminar
ASFALJNI KOLNICE 2018

Internat. seminar ASPHALT
PAVEMENTS 2018

Opatija, 12.–13. 04. 2018

nov 2001: television documentary
exposing collusion & bribery
→ a break down of trust
→ parliamentary inquiry in to fraud
in the construction industry started

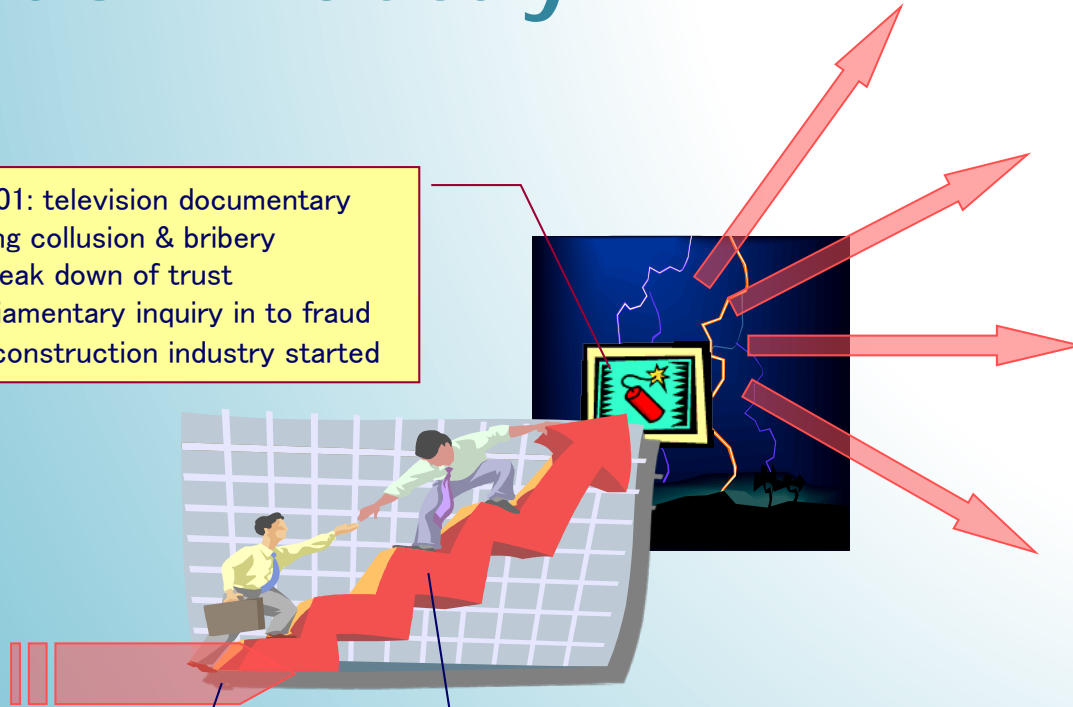

until 1990: dissatisfaction &
adversial relationships

from 1990 onwards: new types of
procurement get introduced

until the 1990's

- design-bid-build procurement was standard
- adversarial relationships & low trust
- several reports were published
 - like the Nedo, Emmerson & Bowley reports in the UK
 - suggesting changes in procurement & culture
- *horizontal* rules for *uniform price regulation* installed to mitigate the perils related to lowest price selection (justified by Dutch ministry Economic Affairs)
 - as winners curse; tendering costs; “Dutch” auctioning
 - contractors signed a code of honour (contaminated projects)



Međunarodni seminar
ASFALJNI KOLNICE 2018

Internat. seminar ASPHALT
PAVEMENTS 2018

Opatija, 12.–13. 04. 2018

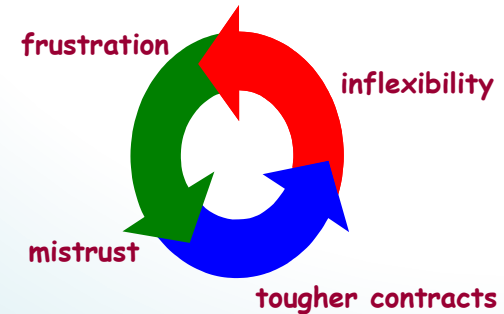

in the 1990's

- EU declared industry's self-regulation illegal (cartel)
- public clients embark on innovative procurement
 - UK seen as a role-model (PFI, Latham, Egan)
 - increasing trust in "the free market" as the coordinating mechanism
 - new policies drafted pressing for innovative procurement
- design-construct got adopted widely agencies for highways, railways etc



Međunarodni seminar
ASFALNI KOLNICI 2018

Internat. seminar ASPHALT
PAVEMENTS 2018

Opatija, 12.–13. 04. 2018



all seemed to go so well

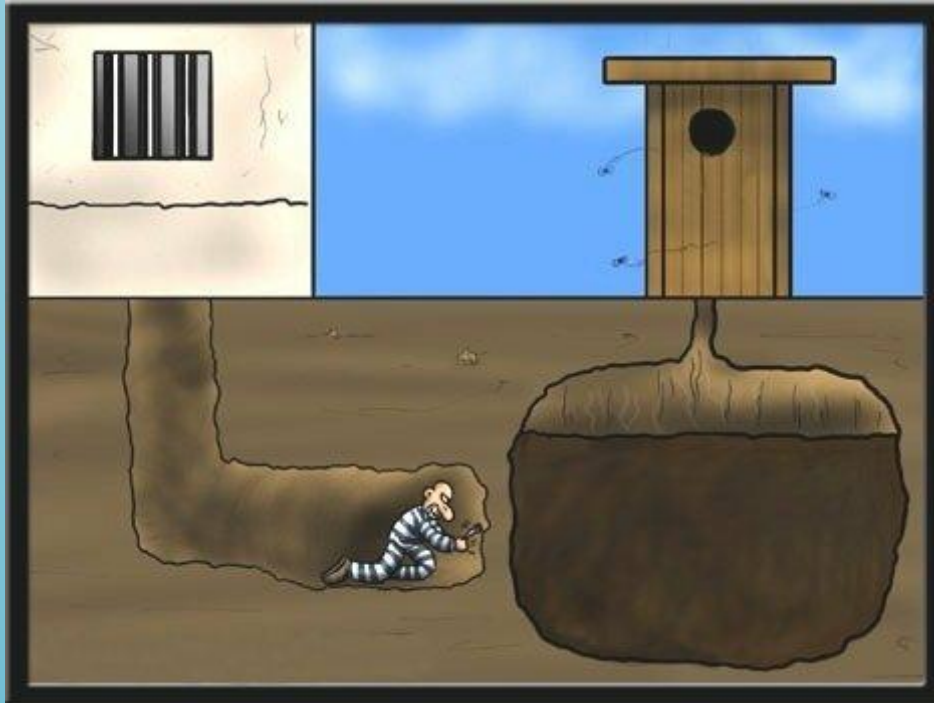

Međunarodni seminar
ASFALJNI KOLNICE 2018

Internat. seminar ASPHALT
PAVEMENTS 2018

Opatija, 12.–13. 04. 2018

ouch

television report on nov 9th 2001

whistle blower presents a phantom account book of the contractors spanning 3500 projects; exposing names & numbers

also making allegations about “grooming & buying” client representatives

“billions of taxpayers money slipped into the pockets of rogue contractors”



3-1996	12.277.000,-	-/-	KWS
12-1997	1.087.000,-	-/-	10.000
07-1998	7.510.000,-	-/-	25.000
07-1998	6.055.000,-	+	22.500
even Saldo per 26-09-97		-/-	41.000
		+	16.000



Međunarodni seminar
ASFALJNI KOLNICE 2018

Internat. seminar ASPHALT
PAVEMENTS 2018

Opatija, 12.-13. 04. 2018





collusion exposed (2001)

- media “smelled blood” → frenzy
- turbulence in national politics (cabinet vs parliament)
- full force investigations:
 - cabinet, dept. of Justice, anti trust agency, fiscal inspectors.
 - unprecedented raids (>500 police; >50 places;)
 - over 80 people were arrested (a dozen jailed >2 wks)
- members of parliament started an inquiry
 - febr 2002- dec 2002
 - live interrogations on TV
 - 3000 plusages report



Međunarodni seminar
ASFALJNI KOLNICE 2018

Internat. seminar ASPHALT
PAVEMENTS 2018

Opatija, 12.–13. 04. 2018



UNIVERSITY TWENTE

www.ASPARi.nl

conclusions



Međunarodni seminar
ASFALNI KOLNICI 2018

Internat. seminar ASPHALT
PAVEMENTS 2018

Opatija, 12.–13. 04. 2018

- bid-rigging and price-fixing (wide spread)
- culture of wining & dining (wide spread)
- bribery (incidents)
- fake invoices (some)
- *asphalt plants were used to run cartels*
- procurement regulation = patch work blanket



in road construction

- anti trust agency forced the industry to redistribute ownership of the asphalt plants
- new types of procurement & contract control
- changing task & responsibilities
- changing definition of Quality



Međunarodni seminar
ASFALJNI KOLNICE 2018

Internat. seminar ASPHALT
PAVEMENTS 2018

Opatija, 12.–13. 04. 2018

The new contract types .



Međunarodni seminar
ASFALJNI KOLNICE 2018

Internat. seminar ASPHALT
PAVEMENTS 2018

Opatija, 12.–13. 04. 2018

- Design-Construct on *functional* specifications
- extension of guarantee period (up to 7-10 years)
- Economically Most Advantageous Tender
- penalty-bonus incentives

... transfer more risks to the contractor

criteria in EMAT as ..

- skid resistance, smoothness, rutting, ravelling, cracks, **water disposal**, reflection, **noise reduction**
- **CO2**, recycling, innovation, **time to completion**, **traffic flow**, **availability**, work windows
- **guarantees**, penalty systems
- risk transfer



Međunarodni seminar
ASFALNI KOLNICI 2018

Internat. seminar ASPHALT
PAVEMENTS 2018

Opatija, 12.–13. 04. 2018

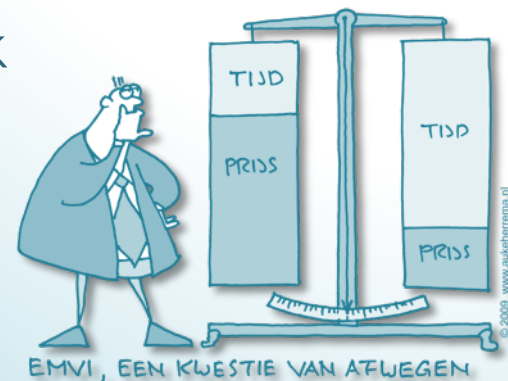

criteria in EMAT as ..

- skid resistance

This trigger provides ...

**opportunities to design new mixes & processes
that outperform competition**

**&
the need to understand how contain the risks**



seminar
NICI 2018
ASPHALT
ITS 2018
04. 2018



EMVI, EEN KWESTIE VAN AFWEGEN

also at that time ...

meanwhile

Concerns over

- aging crews
- troublesome technology introductions
- complex working environment
- strength of technology suppliers
- strength of bitumen suppliers



Međunarodni seminar
ASFALNI KOLNICI 2018

Internat. seminar ASPHALT
PAVEMENTS 2018

Opatija, 12.–13. 04. 2018

ASPARi founders acknowledged...



Međunarodni seminar
ASFALNI KOLNICI 2018

Internat. seminar ASPHALT
PAVEMENTS 2018

Opatija, 12.–13. 04. 2018

Quality is the consequence of process control

- process on site heavily depends on craftsmanship;
- under the new contracts variability of site operations puts contractors at risk
- even more so for a succession of new mixes

*to develop methodical and reliable practices
operators' tacit knowledge must become explicit*

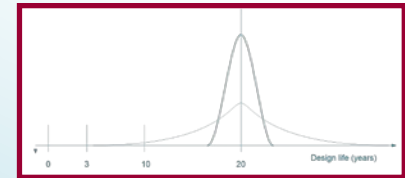

students and
researchers can
help out here



data driven approach...

University Twente

- purchased off the shelf technologies to monitor operations and create a data rich environment
- developed methodologies and protocols
- trained operatives of the contractors
- formed a community of practice
- co-developed tools for analysis and learning

to crack the black box of site operations



Međunarodni seminar
ASFALJNI KOLNICE 2018

Internat. seminar ASPHALT
PAVEMENTS 2018

Opatija, 12.–13. 04. 2018

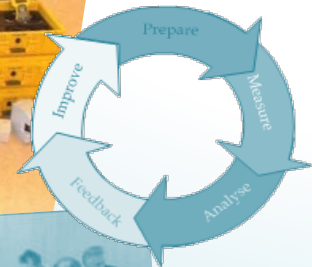

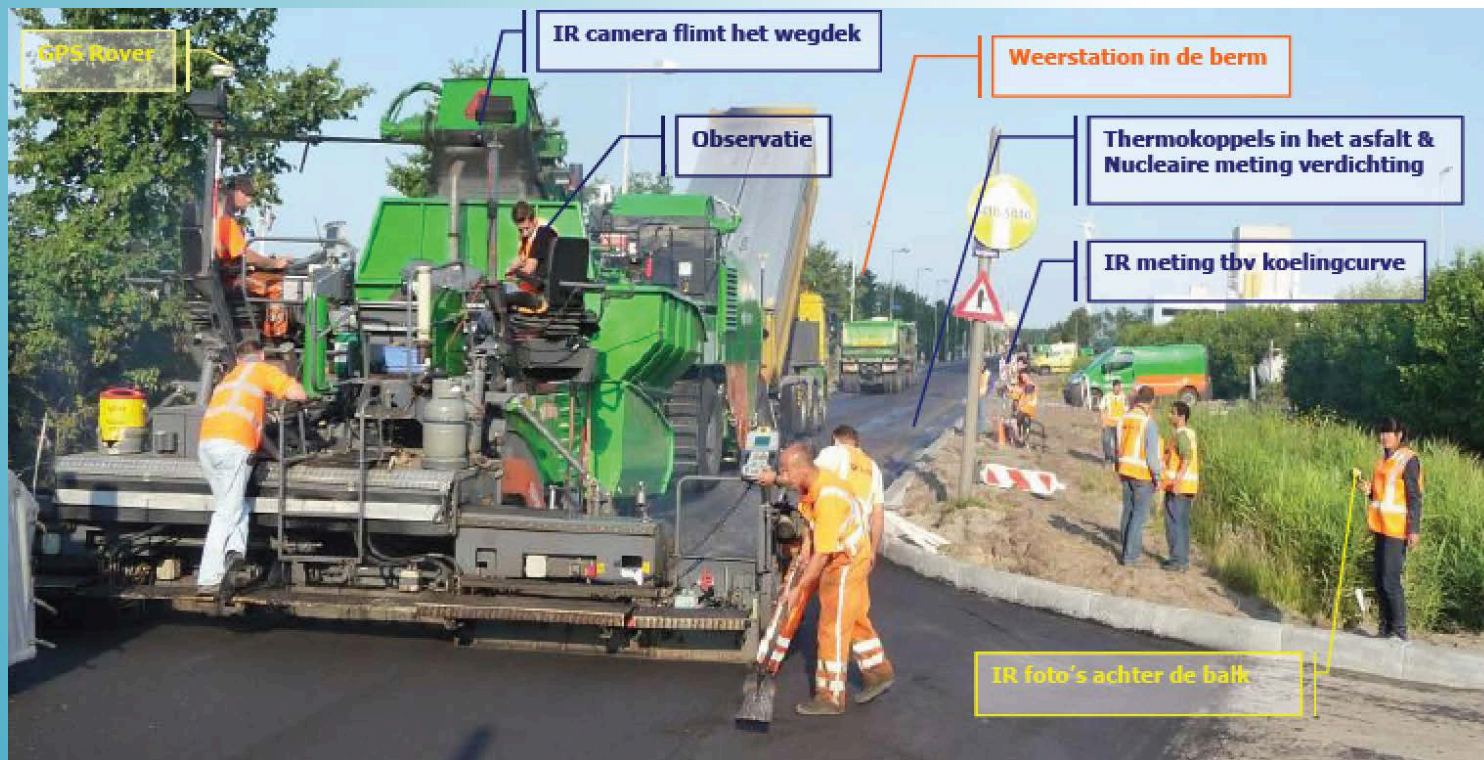

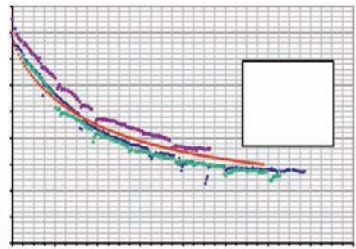
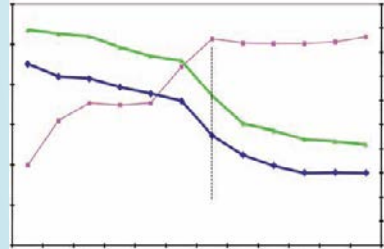
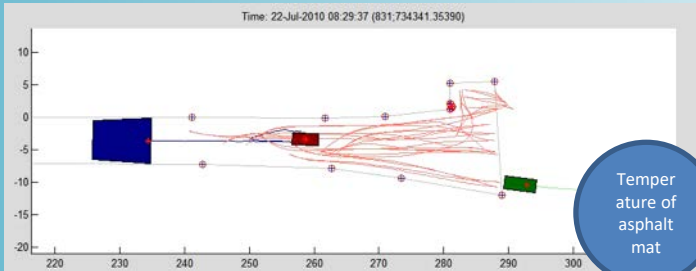

Međunarodni seminar
 ASFALNI KOLNICI 2018
 Internat. seminar ASPHALT
 PAVEMENTS 2018
 Opatija, 12.–13. 04. 2018

creating visuals analytics reports

Temperature of asphalt mat

Number roller passes

Time of asphalt mix delivery

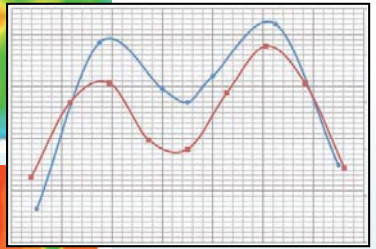
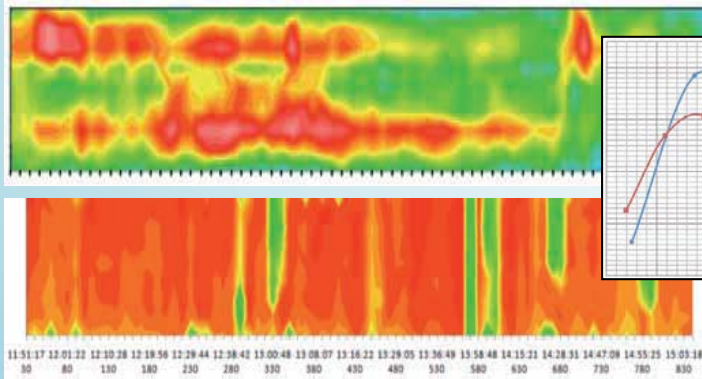
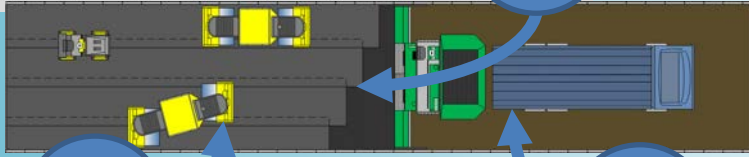

Deploying modern technologies



Međunarodni seminar
ASFALJNI KOLNICI 2018

Internat. seminar ASPHALT
PAVEMENTS 2018

Opatija, 12.–13. 04. 2018

Developing a real-time process control system for asphalt paving and compaction

Denis Makarov, PDEng, 2015-12-16

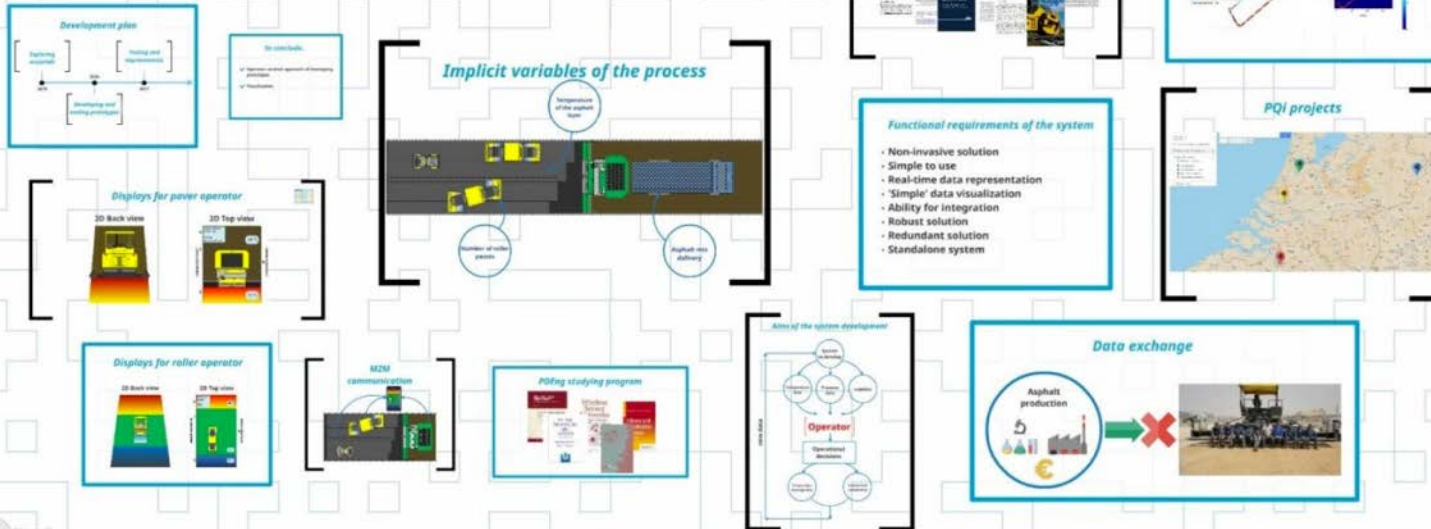

overlays to visualise risks

founders may take it further ...

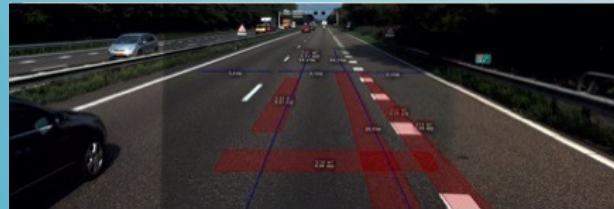
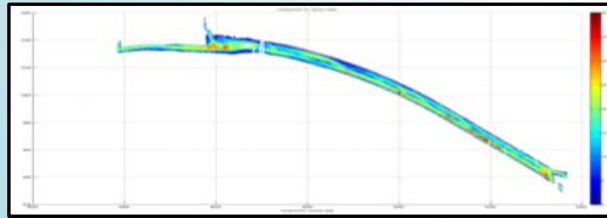
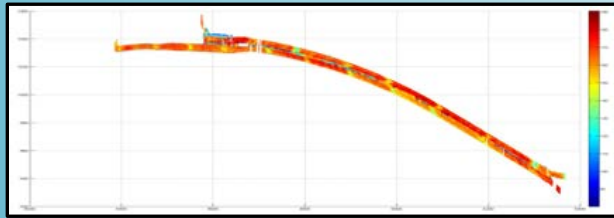

Međunarodni seminar
ASFALJNI KOLNICE 2018

Internat. seminar ASPHALT
PAVEMENTS 2018

Opatija, 12.–13. 04. 2018

case Boskalis
combining PQi data
road scan data

PQI's

over 80 projects analysed

some 'rules':

- minimal two PQI's per contractor per year
- contractors operatives may help out each other
- no talk about IP issues



Međunarodni seminar
ASFALNI KOLNICI 2018

Internat. seminar ASPHALT
PAVEMENTS 2018

Opatija, 12.–13. 04. 2018

- special purpose PQI's
- MTV: shuttle buggy vs feeder
- below zero Celsius paving project
- self healing asphalt paving project
- low temperature mix projects (2)
- South Africa paving projects (2)
- Chili paving project
- airport paving project
- higher speed paving project

ASPAri topics

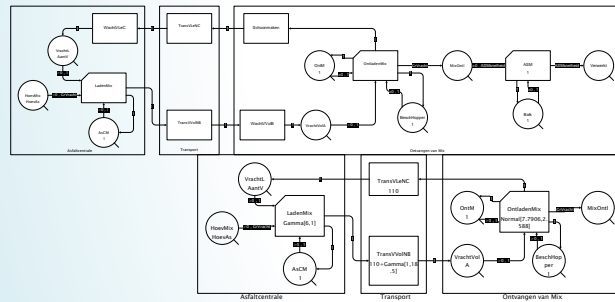

**Međunarodni seminar
ASFALJNI KOLNICE 2018**

**Internat. seminar ASPHALT
PAVEMENTS 2018**

Opatija, 12.–13. 04. 2018

- improving metrics/indicators for process monitoring
- scrutinizing new tech from suppliers (check of sales claims)
- planning/logistics/simulation (reduction of stop-go incidents)
- aligning/calibrating site operation in the lab
- connecting to BIM and other software
- sensors in asphalt (RFID; fiber optics)
- standardization of EMAT criteria
- education (in company, vocational schools)
- educating clients (on techs & contracts)
- reflective crews (double loop learning)

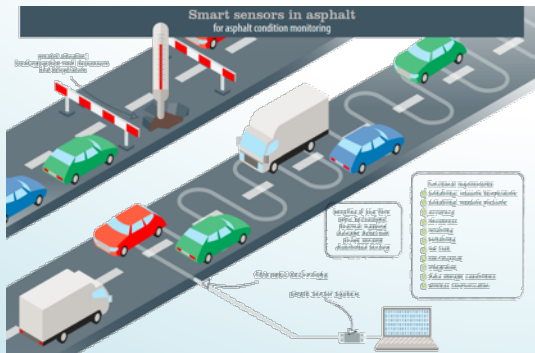



criteria in EMAT as ..

- skid resistance

provides ...

**opportunities to design new mixes & processes
that outperform competition**

**&
the need to understand how contain the risks**



EMVI, EEN KWESTIE VAN AFWEGEN

seminar
NICI 2018
ASPALT
ITS 2018
04. 2018

The Logic of change ... (1)

Schumpeter

- **Dynamic market perspective**
- Reaction on classical economics

- Why do some economies outperform others?
- How do economies grow?

- **Technology renewal**
- **Creative destruction !!**
- **Innovation**



Međunarodni seminar
ASFALJNI KOLNICE 2018

Internat. seminar ASPHALT
PAVEMENTS 2018

Opatija, 12.–13. 04. 2018



Business cycle



Međunarodni seminar
ASFALJNI KOLNICI 2018

Internat. seminar ASPHALT
PAVEMENTS 2018

Opatija, 12.–13. 04. 2018

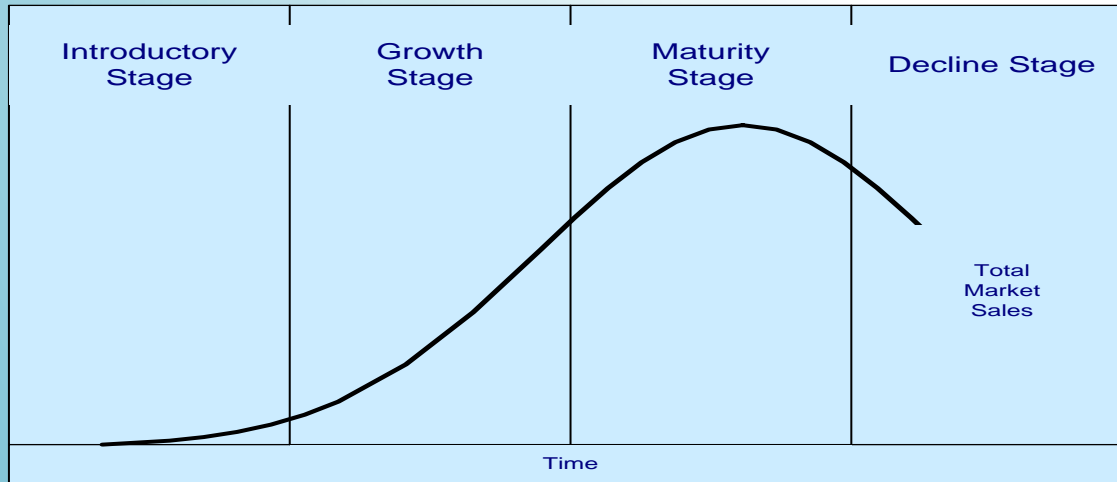

Types of competition

- Not one but four !!!

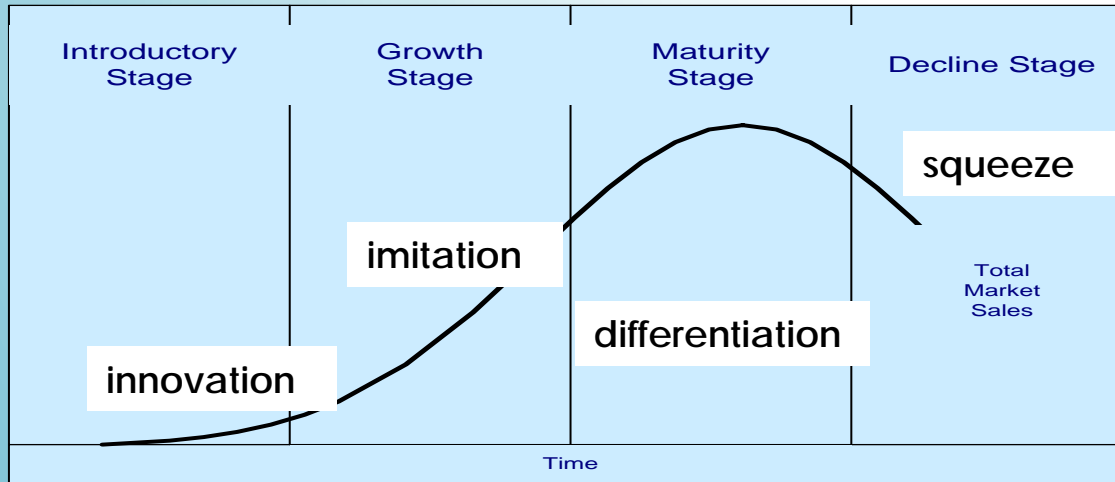

Međunarodni seminar
ASFALJNI KOLNICI 2018

Internat. seminar ASPHALT
PAVEMENTS 2018

Opatija, 12.–13. 04. 2018

Business opportunities ?

- Beware of the squeeze !!!

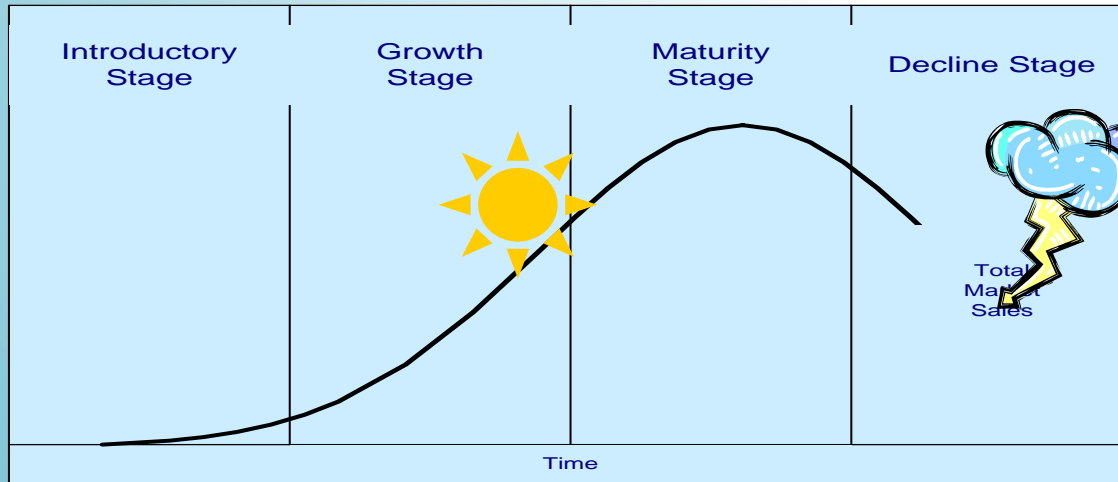

Međunarodni seminar
ASFALNI KOLNICI 2018

Internat. seminar ASPHALT
PAVEMENTS 2018

Opatija, 12.–13. 04. 2018

Business opportunities ?

- Beware of the squeeze !!!

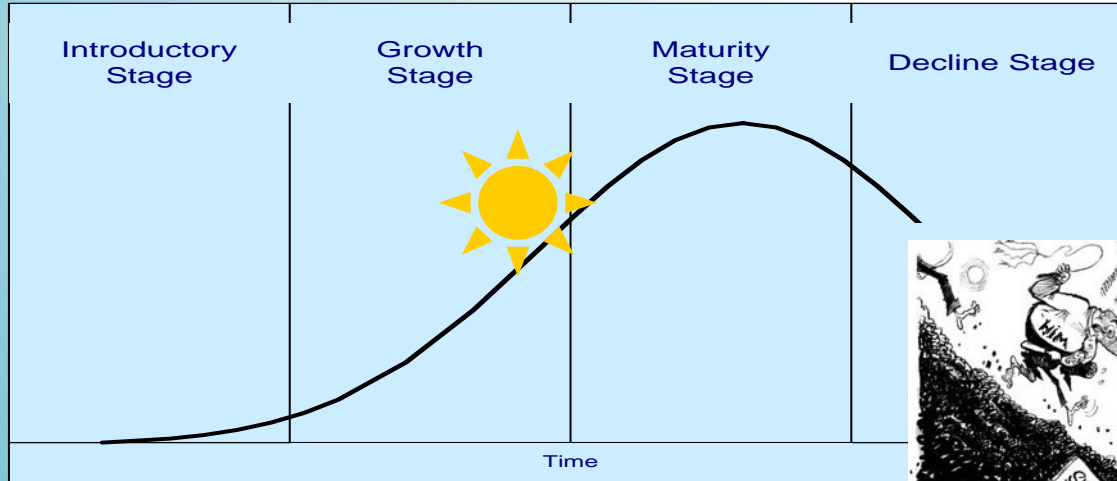

Međunarodni seminar
ASFALJNI KOLNICE 2018

Internat. seminar ASPHALT
PAVEMENTS 2018

Opatija, 12.–13. 04. 2018

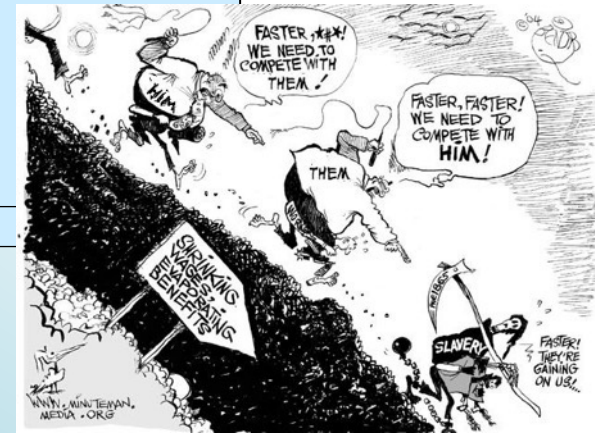

Construction industry

- Traditional design-bid-build

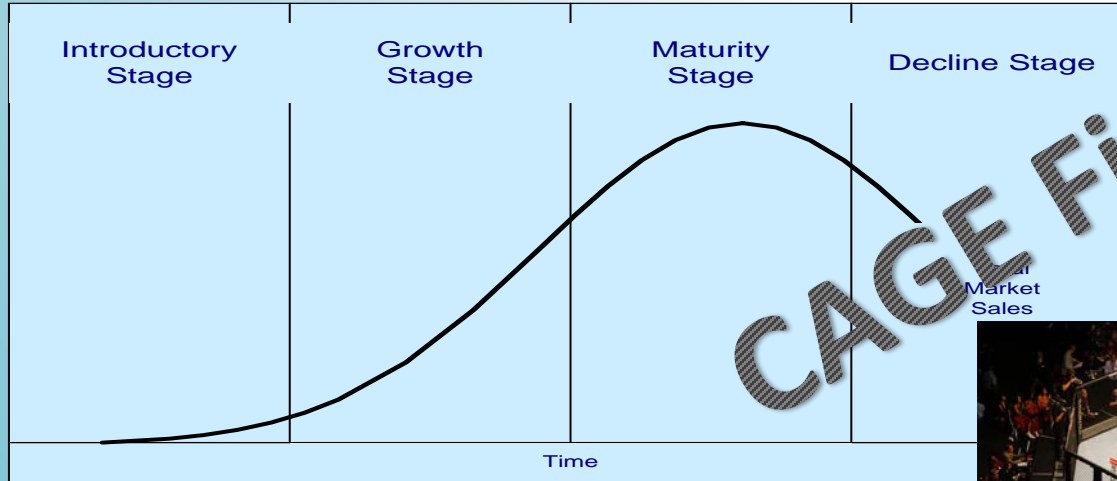

Međunarodni seminar
ASFALJNI KOLNICE 2018

Internat. seminar ASPHALT
POMIČNI POKRETI 2018

Opatica, 12. i 13. 04. 2018

CAGE FIGHT



The Logic of change ... (2)

Traditional contracting: Design-Bid-Build Lowest Bid

- similarity of bids, low margins, race to the bottom,
- poor quality, claim fights & adversarial relationships
- incentive and opportunity for collusion & corruption
- entry barriers to the market are low
- no money to innovate and educate
- detailed specs provide no room/incentive to innovate
- *thus: market misery & limited societal benefit*



Međunarodni seminar
ASFALJNI KOLNICI 2018

Internat. seminar ASPHALT
PAVEMENTS 2018

Opatija, 12.–13. 04. 2018

The Logic of change ... (3)

Integrated contracting: EMAT selection

- competition on solutions, quality & price
- collusion & corruption are more difficult
- competition creates a more positive spiral
- extended guarantee stimulates innovation & quality control
- for contractors it pays off to get smarter

professional industry & societal benefit

*yet: higher risk profiles, complex award processes,
higher tender costs, higher market entry barriers,
confused engineering firms*



Međunarodni seminar
ASFALJNI KOLNICI 2018

Internat. seminar ASPHALT
PAVEMENTS 2018

Opatija, 12.–13. 04. 2018

The Logic of change ... (4)

Public clients pushed for this change

- national clients in the lead
- reforming their staff and expertise
- consistently pursuing the new roles
- creating standards for EMAT criteria
- adding EMAT criteria and procurement types

industry accepting their new roles

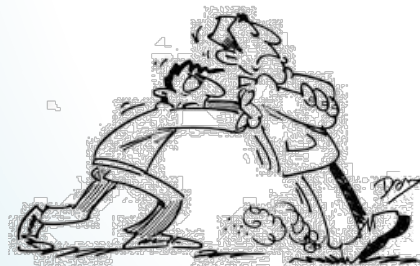

Međunarodni seminar
ASFALJNI KOLNICI 2018

Internat. seminar ASPHALT
PAVEMENTS 2018

Opatija, 12.–13. 04. 2018



ASPARi Founders



- increased their R&D/QC capabilities & skills
- closed the loop for their quality and risk control
- from *artisan craftsmanship* to *professional approaches & understanding* of paving
- take ownership of developing the integrating technologies they need rather than believing the suppliers' *total solutions*,
- HR: professional pride, empowered staff & influx of MSc

from *reactive jobbers*
to *professional developers/providers*
of products/processes in paving

Međunarodni seminar
ASFALNI KOLNICI 2018

Internat. seminar ASPHALT
PAVEMENTS 2018

Opatija, 12.–13. 04. 2018

Initial concerns

- guarantee and quality risks
- aging crews
- troublesome technology introductions
- complex working environment
- strength of suppliers



Međunarodni seminar
ASFALNI KOLNICI 2018

Internat. seminar ASPHALT
PAVEMENTS 2018

Opatija, 12.–13. 04. 2018



What is next

the ASPARi 2018-2023 program

- pushing for interconnectivity on site & site-office
- educating modules for schools and clients
- setting standards for technology suppliers
- redesigning laboratory test that predict 'workability'
- virtualization of the asphalt plant and site operations
- scoping EMAT criteria towards robustness (e.g. circularity)
- sensors and end-of-lifetime prediction
- automation and crew size reduction (smaller higher educated crews)



Međunarodni seminar
ASFALJNI KOLNICE 2018

Internat. seminar ASPHALT
PAVEMENTS 2018

Opatija, 12.–13. 04. 2018



To conclude

the exposed collusion is taken as *a blessing in disguise*

- EMAT procurement created a positive industry dynamic
- companies have become more professional
- innovation creates benefits for industry and society
- increased industry pride, esteem and reputation



Međunarodni seminar
ASFALJNI KOLNICI 2018

Internat. seminar ASPHALT
PAVEMENTS 2018

Opatija, 12.–13. 04. 2018



ASPARI
paving the way forward

UNIVERSITY TWENTE
www.ASPARi.nl

ASPARi lessons for Croatia....?

- low cost competition prevents innovation
- despair may push for creative fraud
- clients are the leaders in industry change
- master 'the art' of functional specs and EMAT
- EMAT makes it possible to differ for the better
- differentiation generates innovation & industry pride
- EMAT must have a significant impact over price



Međunarodni seminar
ASFALJNI KOLNICI 2018

Internat. seminar ASPHALT
PAVEMENTS 2018

Opatija, 12.–13. 04. 2018



acknowledgements

CAA for invitation & opportunity to tell the ASPARi story in Croatia

- **NL Highway agency** for susceptibility to the insight that departure from “design-bid-build low bid” was vital for creating a mature road building industry
- **Founders & their people** for their leadership, support & commitment to ASPARi
- Dr Seirgei Miller as ASPARi’s 1st PhD, Principal investigator Anchorman
- PDEngs, PhDs & students for the efforts, smarts and surprising perspectives

thank you for your attention



Međunarodni seminar
ASFALJNI KOLNICI 2018

Internat. seminar ASPHALT
PAVEMENTS 2018

Opatija, 12.–13. 04. 2018



FOR FURTHER INFORMATION

WWW.ASPARI.NL

prof.dr.ir.ing **André Dorée**

faculty of Engineering Technology

head of dept Construction Management & Engineering

chair of market- & organisation dynamics

T: xx-31 534894058 | M: xx-31 651259710

E: a.g.doree@utwente.nl | [skype: adoonskype](https://www.skype.com/join/adoonskype)

UNIVERSITY TWENTE | pobox 217 | 7500 AE ENSCHEDE



Međunarodni seminar
ASFALJNI KOLNICI 2018

Internat. seminar ASPHALT
PAVEMENTS 2018

Opatija, 12.–13. 04. 2018

UNIVERSITY TWENTE – Civil Engineering

dept Construction Management & Engineering

- integration & innovation in fragmented construction industry
- interfaces foci: Markets, Organisation, Technologies, People
- engaged scholarship approach
- knowledge domains: Systems Eng, BIM/ICT, Asset Management
- experience/data domains: road building, utilities, city engineering



Međunarodni seminar
ASFALJNI KOLNICI 2018

Internat. seminar ASPHALT
PAVEMENTS 2018

Opatija, 12.–13. 04. 2018

*integration & innovation in
the fragmented
construction industry*

