

# The development and use of the Skid Resistance and Smart Ravelling Interface Testing Device

Radjan Khedoe<sup>1, a</sup>, Arian de Bondt<sup>1</sup>, Mirella Villani<sup>2</sup>, Tom Scarpas<sup>2</sup>

<sup>1</sup> Ooms Civiel, Scharwoude, Netherlands

<sup>2</sup> Faculty of Civil Engineering & Geosciences, Delft University of Technology, Delft, Netherlands

<sup>a</sup> rkhedoe@ooms.nl

Digital Object Identifier (DOI): [dx.doi.org/10.14311/EE.2016.290](https://doi.org/10.14311/EE.2016.290)

## ABSTRACT

*Since June 2012, tyre manufacturers have been required to provide data in relation to the performance of their tyres through testing. The tyre label covers rolling resistance, wet grip or skid resistance, noise emission. These are important criteria to consider. In the future this kind of labelling system will be applied on roads. In such a case it is not desirable to build costly test sites to evaluate these criteria. There is a need of accurate laboratory testing device to perform such tests.*

*Currently available lab and field friction testing devices do not allow for the evaluation of the interaction between relative speed, pressure and temperature on friction. A Skid Resistance & Smart Ravelling Interface Testing Device (SR-ITD®) has been designed and built for the study of the influence and the interaction of the various phenomena occurring at the rubber pavement interface. The device enables various combinations of slip velocity and pressure to be applied with concurrent measurement of temperature in the interface regions. With this device it is also possible to study the ravelling resistance of a surfacing material (asphalt, concrete or a surface dressing). The device was developed to study and evaluate materials in the laboratory on a smaller scale and much faster than in real practice. The materials to test can be the rubber on the tyres or the surface of the road, asphalt, concrete or other surface materials. This paper will describe the development and use of the machine till current date.*

*An optimal tyre can only be developed with a representative road surface also an optimal road surface can only be developed with a representative tyre. With accurate testing devices the interaction between tyre and road can be solved.*

**Keywords:** Ravelling, Rubber tyres, Skid Resistance, Surface Texture

## 1. Introduction

It is well known that the interface of the tyre of a car and the pavement is important for the different interactions, in terms of safety. Skid resistance is an important factor for traffic safety. It describes the contribution of the road surface to the development of friction at the tyre-road interface. Friction originates primarily from the interaction of the asperities of the road surface with the morphological characteristics of tyres.

The interaction between tyre and road is preferably known before production. For the road authorities and contractor the quality of the road surface after construction and during service life is important. The tyre industry is interested in the safety provided by the tyre. The two industries operate from their own point of view. Separately they build costly test sites (tracks) or test devices for characterizing their products. But the interactions at the interface as they happen in practice, are less explored.

A tyre is recognized as a high-performance composite with more than sixty different materials and it is quite possibly the most complex part of a car. Among those components, the one that is directly at the tyre-pavement interface is the tread. The tyre properties and the tread properties are strongly related since, amongst others, the traction of a tyre is dictated by the friction properties of the tread compound. The handling characteristics of a tyre depend on the stiffness of the tread compound. The rolling resistance depends on the loss modulus of the tread compound. And finally tyre heat build-up depends on the rubber thermal conductivity.

Also, currently available lab and field friction testing devices do not allow for the evaluation of the interaction between relative speed, pressure and temperature on friction. In the framework of the EU FP7 SKIDSAFE project, an innovative Skid Resistance & Smart Ravelling Interface Testing Device (SR-ITD<sup>®</sup>) has been designed and built for the study of the influence and the interaction of the various phenomena occurring at the rubber and pavement interface [1].

## 2. Development of a new laboratory testing device

Currently available laboratory and field testing devices can test friction. But they do not allow for the evaluation of the interaction between relative speed, pressure and temperature on friction. Also they can either polish the specimen or perform a friction test. The reaction forces, temperature, etc. are not measured during polishing. Also the temperatures at the interface during skid resistance testing are not measured.

In the framework of the EU FP7 SKIDSAFE project, an innovative (and patented) Skid Resistance & Smart Ravelling Interface Testing Device (SR-ITD<sup>®</sup>) has been designed and built to meet the demands described above.

During the development of this test device the criteria for proper interface testing were formulated. Representative test conditions should be created, like loading stresses, speed and temperatures. Good quality specimens of asphalt or stone and rubber from a tyre are to be used in the test. The test system should not be a black box, so it should consist of adequate and reliable instrumentation which can provide high measurement accuracy and produce understandable output.

From the criteria described above, the set of demands for the interface testing device was formulated. High travel speeds with representative normal pressures (of a car or a truck) and simulation on dry as well as wet surfaces should be possible. Wheels of the device should have the possibility of different wheel slips. It should be suited for stone, cement concrete and asphalt surfaces. The test must be efficient and cost-effective. Measurements and polishing should be possible simultaneously. Scientific interpretation and utilization of the output data should be possible.

This resulted in a design for a prototype of the interface testing device. All the machine parts were designed in a three-dimensional design software, and 3D rendered (Figure 1) for some practical mechanical validation. After the design validation, the 3D design was converted to 2D AutoCAD drawings for production of the parts. All the design parts of the machine were custom made in a mechanical workshop. The assembly of the machine was done at the laboratory of Ooms Civiel, in Scharwoude, the Netherlands.

The SR-ITD was designed with the main purpose of enabling the investigation of the influence of various combinations of rubber tyre pressure, skid velocity and traffic load repetitions on the surface characteristics of pavements. In the course of a test, all three parameters can be varied individually or kept constant. In this way, the device provides an attractive alternative to standard types of equipment which are currently utilized for (in-situ) skid resistance and/or polishing measurements and which do not provide any user control nor understanding of the actual test conditions imposed by the equipment on the material(s).

## 3. Skid Resistance & Smart Ravelling Interface Testing Device

The Skid Resistance & Smart Ravelling Interface Testing device or SR-ITD consists of two key components, as it is shown in Figure 1 and Figure 3: a moveable turntable or sample holder onto which the asphalt concrete specimen with a diameter of 390 mm is placed and a static loading frame onto which three rubber wheels are installed. Individually each wheel can be placed at variable radii from the centre (Figure 2) and at various slip angles and can be rolling (in this case angular speed can be measured) or fully fixed. A maximum speed of 85 km/h can be reached when the wheel is placed in the outer position.

Each solid rubber wheel is 100 mm in diameter and has a width of 25 mm. The wheels are not meant to represent complete tyres. SR-ITD has been designed for the investigation of rubber-pavement surface interaction.

Each wheel is instrumented in order to record:

- normal, tangential and longitudinal forces;
- angular speed of the wheel;
- external and internal temperature of the rubber tyre in different locations with different instruments (external sensors and implanted thermocouples) as well as the cooling water temperature.

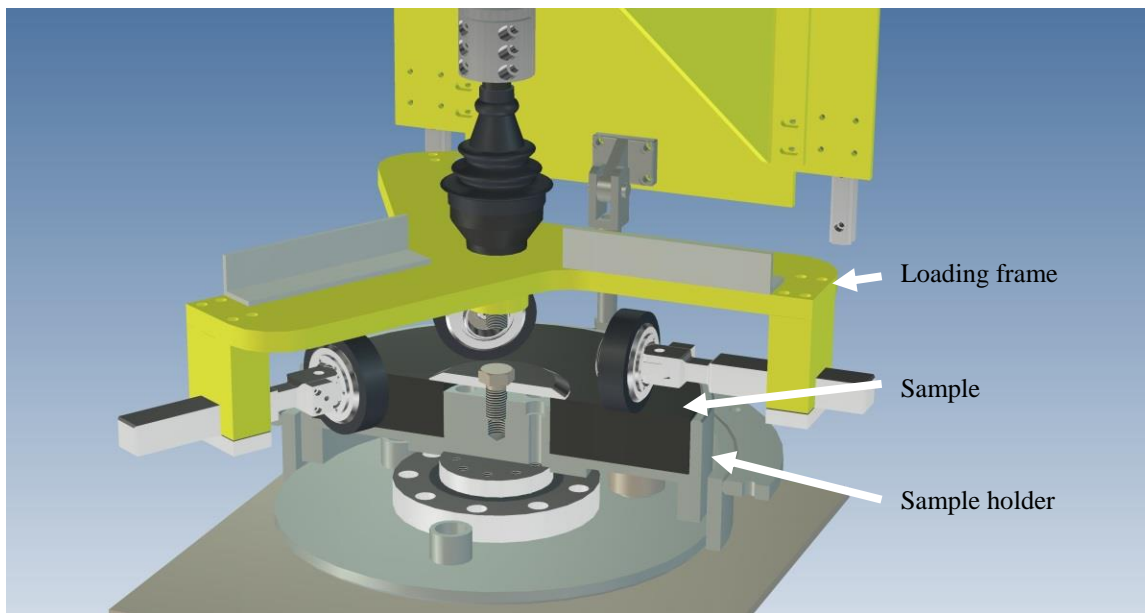

**Figure 1: 3D rendering of the SR-ITD**

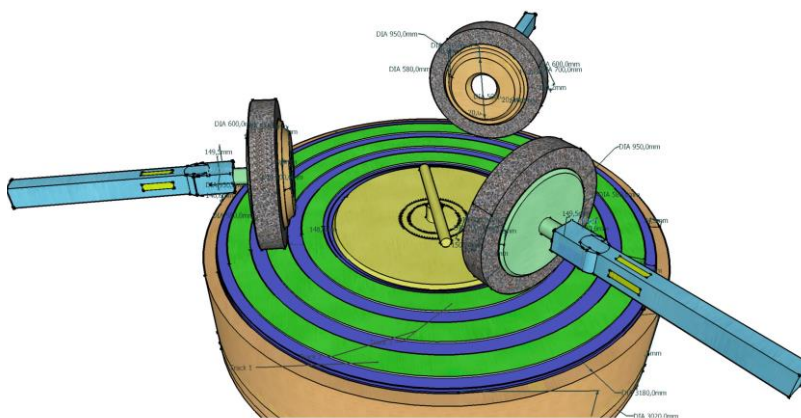

**Figure 2: Three variable radii on the sample**

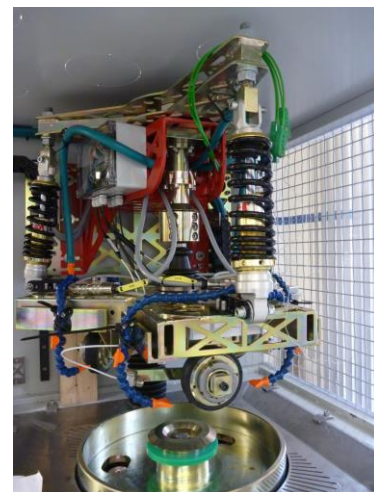

**Figure 3: The SR-ITD set-up**

The movement and force in vertical direction of the loading frame is induced by a pneumatic controlled and measured cylinder. This pneumatic cylinder is connected with a piston to the loading frame. This system can work with air pressures up to 7.2 bar. The loading frame has three wheels for stability and the fact that in this way more data is generated in one test, to make it more efficient. The wheel construction is designed in such a way, that the rubber tyres

that are mounted on a steel wheel rim can easily and quickly be replaced. The wheel rim is attached on a stainless steel axle. This axle is connected to a multi axis load sensor.

Custom made machine control and data acquisition software was designed and built for the device. The data acquisition can record the output of the load sensors, the pressure of the loading frame on the sample, temperatures and the rotating speed of the sample.

#### 4. Instrumentation of the SR-ITD

The moveable turntable is connected by a driving shaft to an electric motor. This motor can drive the specimen and turntable with a mass of 50 kilograms up to 1250 rotations per minute. This corresponds to a speed of 85 km/h when the wheel is placed in the outer position. The speed is controlled and measured. The rotational speed of the individual wheel can also be measured.

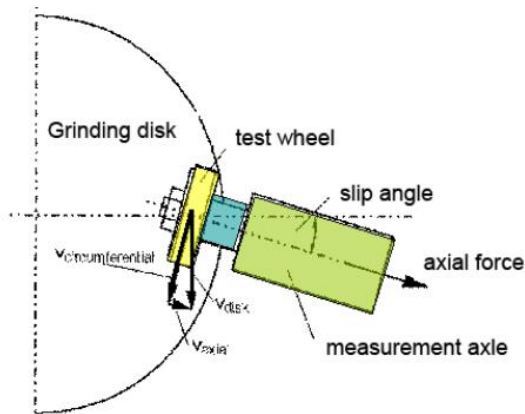

Figure 4: Angled wheel on rotating specimen



Figure 5: Multi axis load sensor

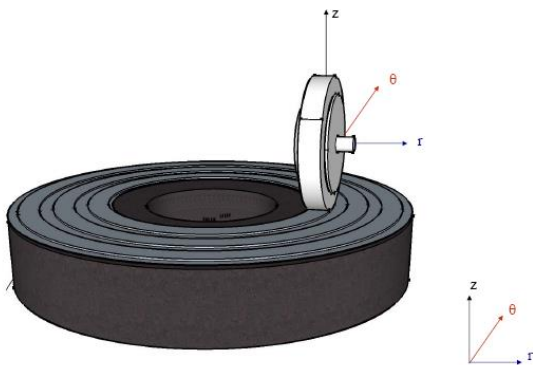

Figure 6: Definition of the three axes of the system - 'Z' (vertical) 'r' (axial) and 'θ' (tangential)



Figure 7: Thermocouples in rubber sample

Skid resistance is created by changing the angle of the wheel (Figure 4). The difference between the speed of the road surface sample and the circumferential speed of the rubber wheel is the slip speed. This will introduce a force in the axial direction. The friction coefficient can be calculated from the measured forces. The SR-ITD is instrumented with a multi axis load sensor (Figure 5) in order to record normal, tangential and longitudinal forces. Multi axis load sensors are designed to measure a multiple of forces simultaneously. It can measure forces up to  $\pm 1000$  N in three directions. The three axes are defined as 'Z' (vertical) 'r' (axial) and 'θ' (tangential) (Figure 6).

The internal temperature of the rubber can be measured by means of implanted 'K type' thermocouples installed via a small hole (10 mm long) in three locations of the rubber sample. One thermocouple is installed at 4 mm from the rubber-asphalt interface and the other two are located closer to the ring, which can be seen in Figure 7. The inside temperature can only be measured from a fixed non-rotating wheel. The surface temperature of the rotating rubber wheels and road surface sample is monitored by infrared thermometers.

The interface measurements can be performed at different moisture conditions. Therefore a water spray system is part of the SR-ITD. The water is pumped from a reservoir into the machine and sprayed in front of the contact area of the rubber tyre and surface of the specimen to be tested, either stone or asphalt. The flow of water is controlled and measured. The amount of water can be monitored with calibrated flow meters. The temperature of the water is also monitored.

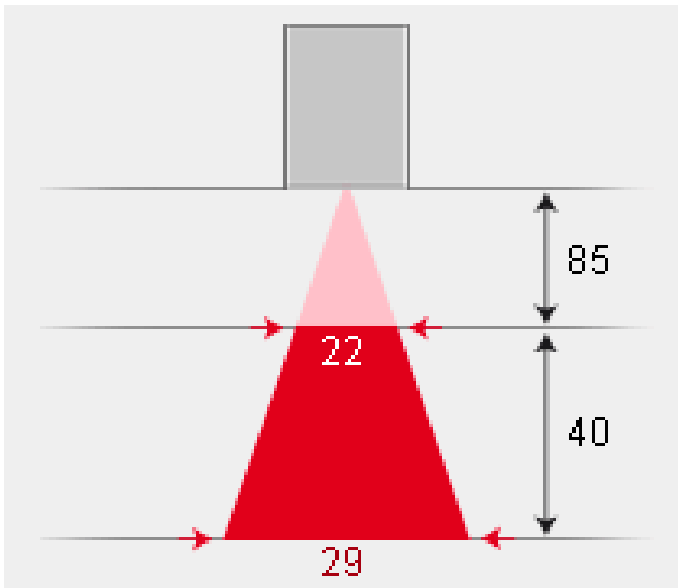

Figure 8: Measuring range of 3D laser line scanner



Figure 9: Scanner in SR-ITD

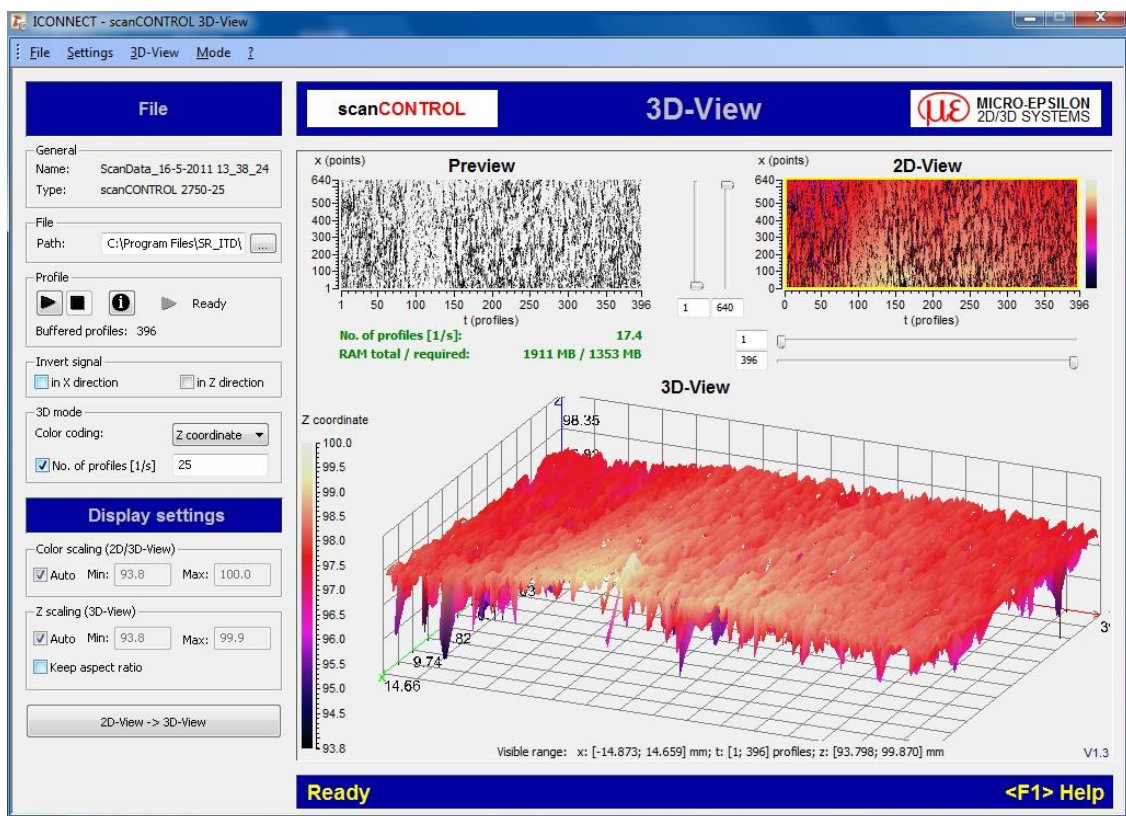
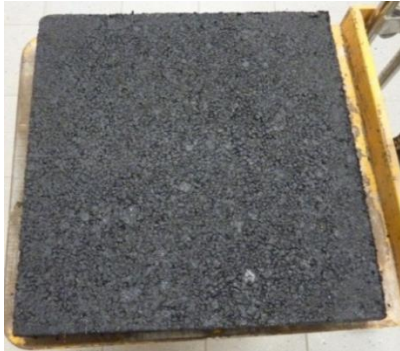

Figure 10: Typical output of surface roughness measurement

The test samples like stone aggregate, asphalt concrete or other material, will see some polishing by the rubber tyres in time due to the representative loading. The polishing effect will influence the skid resistance of a certain material. To monitor the polishing of the test samples, a 3D laser line scanner is used (Figure 8, 9 and 10). The 3D laser line scanner uses the triangulation principle for a two dimensional acquisition of a height profile of various target surfaces. The profiles of the laser scan can be analysed by means of fractal analysis techniques. [2]

## 5. Materials to test

The road surface specimen can be produced in the laboratory or extracted from a road. In the laboratory a sample can be prepared by production of a slab with the dimensions 500 mm x 500 mm x 60 mm of the desired asphalt mixture (Figure 11) with an automated laboratory asphalt roller compactor. From this slab a sample is cored with a diameter of 390 mm. (Figure 12) The sample is then ready for testing. A sample can also be extracted from the road. This procedure can also be applied for concrete and stone slabs. The stone specimen can be cored out of large aggregates from the quarry (Figure 14). The surface of the stone slabs have to be roughened after cutting [3].



**Figure 11: Asphalt concrete slab produced in laboratory**



**Figure 12: Coring of asphalt sample with a diameter of 390 mm**



**Figure 13: Sample in SR-ITD**



**Figure 14 Coring of stone sample with a diameter of 390 mm**



**Figure 15: Stone samples**



**Figure 16: Rubber test wheel**

The SR-ITD has been designed for investigation of rubber-pavement surface interaction characteristics. The rubber is thus also an important component in the test. The solid rubber wheel can be produced by rubber manufacturers at desired representative specifications, which is of great importance. Each rubber wheel is 100 mm in outer diameter and has a width of 25 mm.

## 6. Test possibilities with the SR-ITD

The device has been developed to study and evaluate materials in the laboratory on a smaller scale and much faster than in real practice. The materials to test can be the rubber on the tyres or the surface of the road: asphalt, cement concrete or other surface materials. Four test procedures will give an idea of the test possibilities of this (patented) interface test device.

### 6.1 Initial skid resistance

On the motorways in the Netherlands the majority of surface layers is porous asphalt. After construction, a porous asphalt surface layer cannot be spread with an overload of crushed sand to achieve initial skid resistance. This would fill the voids of the asphalt. The only lasting solution is to remove the binder film on the surface, to expose the aggregate. This will improve the skid resistance. This will happen over time, when the traffic will run over the surface.

Dutch road authorities demand a certain level of initial skid resistance on the motorway after construction. This is only tested after the road is paved and before the road is opened to traffic. This test is only performed in practice, on a test site or on the new road. If the minimum initial skid resistance is not met, the road cannot be opened and the asphalt surface layer has to be reconstructed.

This phenomenon creates risks for the contractor if he applies a new kind of porous asphalt. He can produce of course first (costly) test sites (trials) to ensure the initial skid resistance on the road. Another way to ensure an initial skid resistance, is the use of a topping material, which is applied on the asphalt directly behind the paver screed. Hereafter, the roller compaction is performed. The optimum amount can be determined with costly and time consuming test sites.

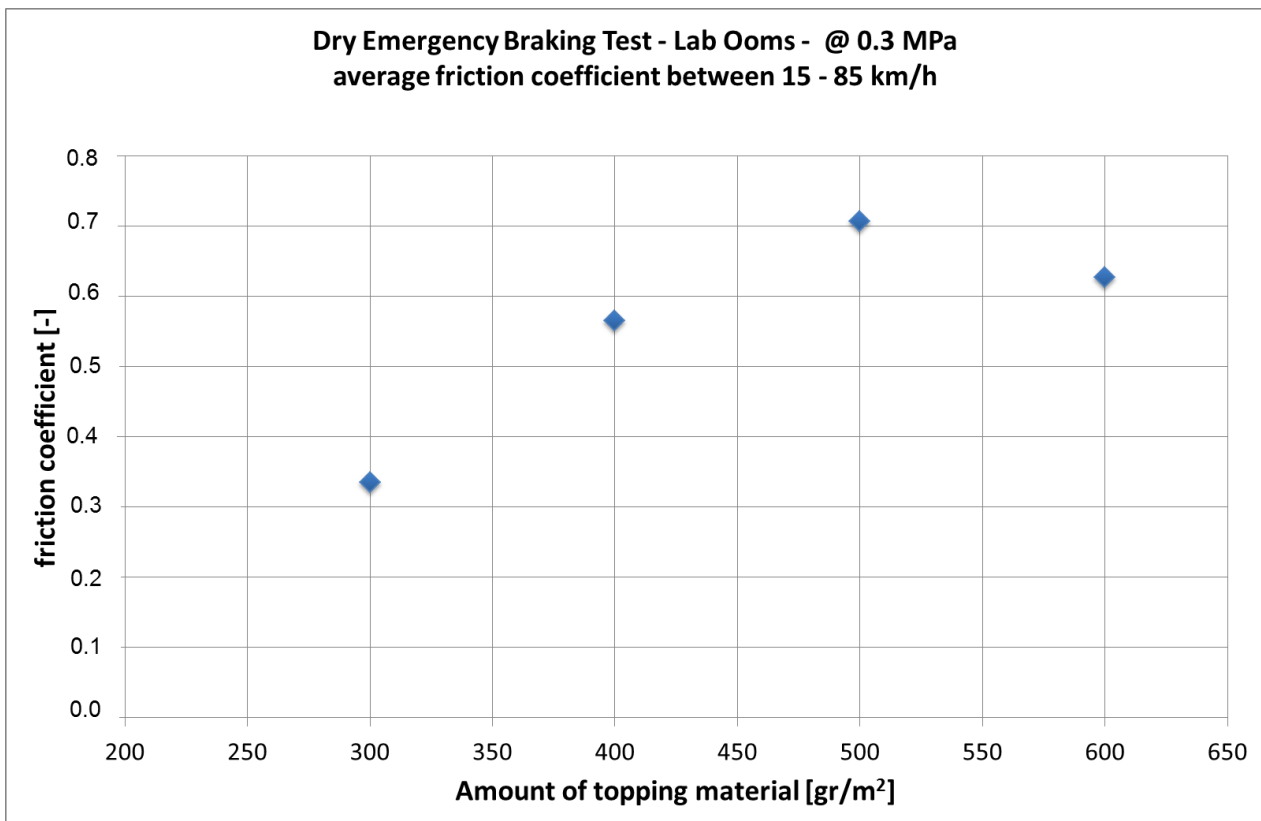

**Figure 17: Typical result of the average friction coefficient between 15-85 km/h in SR-ITD during dry emergency braking test for different amounts of topping material**

The initial skid resistance can be determined more efficiently and cost-effectively in the laboratory with the SR-ITD. Samples of the desired road surface are made in the laboratory. These samples are tested in a so-called dry emergency braking procedure. A series of braking tests are performed in order to evaluate the initial frictional characteristics. In order to perform the braking test, the frame is lowered onto the asphalt specimen that it is rotating. The three wheels attached to the frame are placed at an equal distance from the rotation centre, in the most outer track. Two wheels are freely rolling while the measuring wheel is locked. The speed is decreased linearly from 85 km/h to 0 km/h in 6 seconds. A constant pressure of 0.3 MPa beneath the wheels is applied via the loading frame, simulating a passenger car. Three replicate tests are typically performed. A typical result is displayed in Figure 17.

Based on the laboratory results the contractor can decide to construct only one test site or directly construct the intended surface layer on the motorway.

## 6.2 Skid resistance of road surface during service life

During the service life of an asphalt surface pavement layer the skid resistance varies. The initial skid resistance is not so high, due to the binder film. The skid resistance increases as the bitumen on the surface of the aggregate is worn away. In the last stage, the polishing of the exposed aggregate influences the skid resistance. Friction will decrease during time after so many load cycles caused by traffic. The polishing resistance will be dependent on the type of aggregate and mixture composition. The experimental characterization of the friction properties of different asphalt mixtures, after different loading or polishing cycles can be carried out by means of the SR-ITD.

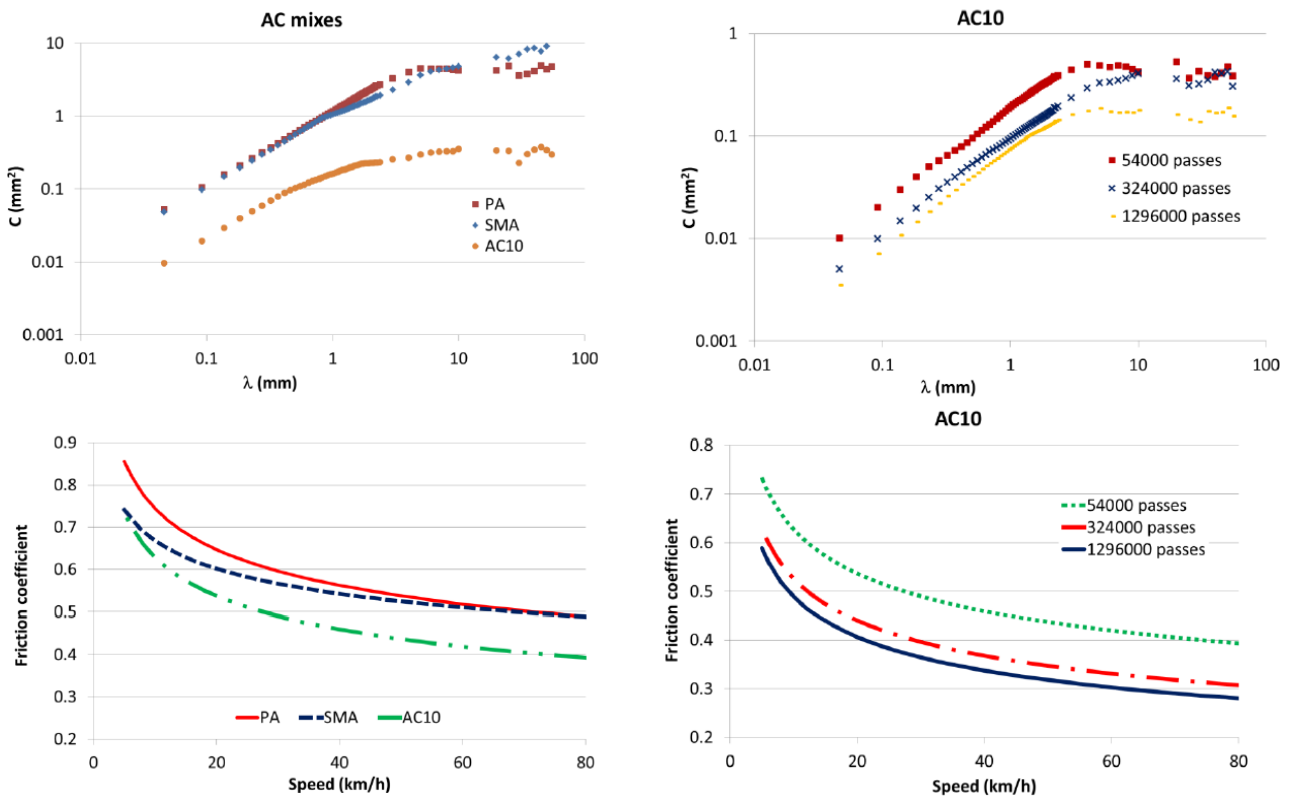

**Figure 18: Typical example of fractal analysed surface characterization of different mixtures and friction characterization (left). fractal analysed surface characterization and frictional characterization for different 3 polishing levels (right).**

With respect to the surface textures, the results are obtained after the bitumen film is removed. In order to do the latter, the three wheels of the SR-ITD are placed at an angle of 5 degrees with respect to the direction of rotation and are rolling with a speed of 20 km/h on the asphalt surface under a pressure of 0.3 MPa for 54000 passes. Cooling water is sprayed directly in front of the test wheels with a rate of 3 l/min at a temperature of 20 °C. After bitumen film removal, a series of braking tests are performed in order to evaluate the frictional characteristics. To conduct the braking test, the frame is lowered on the AC specimen that it is rotating. The three wheels attached to the frame are placed at an equal distance from the rotation centre. Two wheels are freely rolling while the measuring wheel is locked. Cooling water is sprayed directly in front of the test wheels with a rate of 3 l/min at a temperature of 20 °C. The speed of the specimen is decreased linearly from 85 km/h to 0 km/h in 6 seconds. A constant pressure of 0.3 MPa (simulating a passengers car) beneath the wheels is applied via the loading frame. Three replicate tests are typically performed. This procedure is repeated several times until more than 1 million load repetitions have been carried out, to measure the development of skid resistance during service life. (Figure 18)

Fractal analyses [2] can be performed in order to quantify the morphological characteristics of each asphalt material type. The output is a height difference correlation ( $c$ ) versus wave length ( $\lambda$ ) graph. A typical example of the influence of polishing cycles on the morphological characteristics of the surface of a few asphalt mixtures is shown in Figure 18. Polishing affects primarily the higher wave lengths.



### 6.3 Skid resistance of rubber tyre

Tyre manufacturers are interested in the best and most cost effective rubber compound for the tread of the tyre. Since June 2012, tyre manufacturers have been required by the EU to provide data in relation to the performance of their tyres through testing. The tyre label covers rolling resistance, wet grip or skid resistance and noise emission. These are important criteria to consider. In future this kind of labelling system might also be applied on roads. In such a case it is not desirable to build costly test sites to evaluate these criteria for each new mixture. There is a need for an accurate laboratory testing device to perform such tests.

The procedure of characterizing skid resistance of rubber tyres on different road surfaces in the SR-ITD is as follows. The results of the friction tests are obtained after the bitumen film is removed from the asphalt sample. The bitumen film removal procedure was described in the previous section.

After bitumen film removal, a series of braking tests are performed in order to evaluate the frictional characteristics. First the frame is lowered on the AC specimen that it is rotating. The three wheels attached to the frame are placed an equal distance from the rotation centre. All the three wheels are freely rolling. Each wheel is positioned at a different angle, 5, 10 and 15°. Cooling water is sprayed directly in front of the test wheels with a rate of 3 l/min at a temperature of 20 °C. The speed of the pavement specimen is linearly increased and decreased linearly from 0 km/h to 85 km/h to 0 km/h in 48 seconds. A constant pressure of 0.3 MPa (simulating a passenger car) beneath the wheels is applied via the loading frame. Three replicate tests are typically performed. Figure 19 displays the average results of the different combinations of type of rubber compound and pavement surface.

From this result the tyre manufacturer can for example choose the rubber compound which performs overall the best in skid resistance.

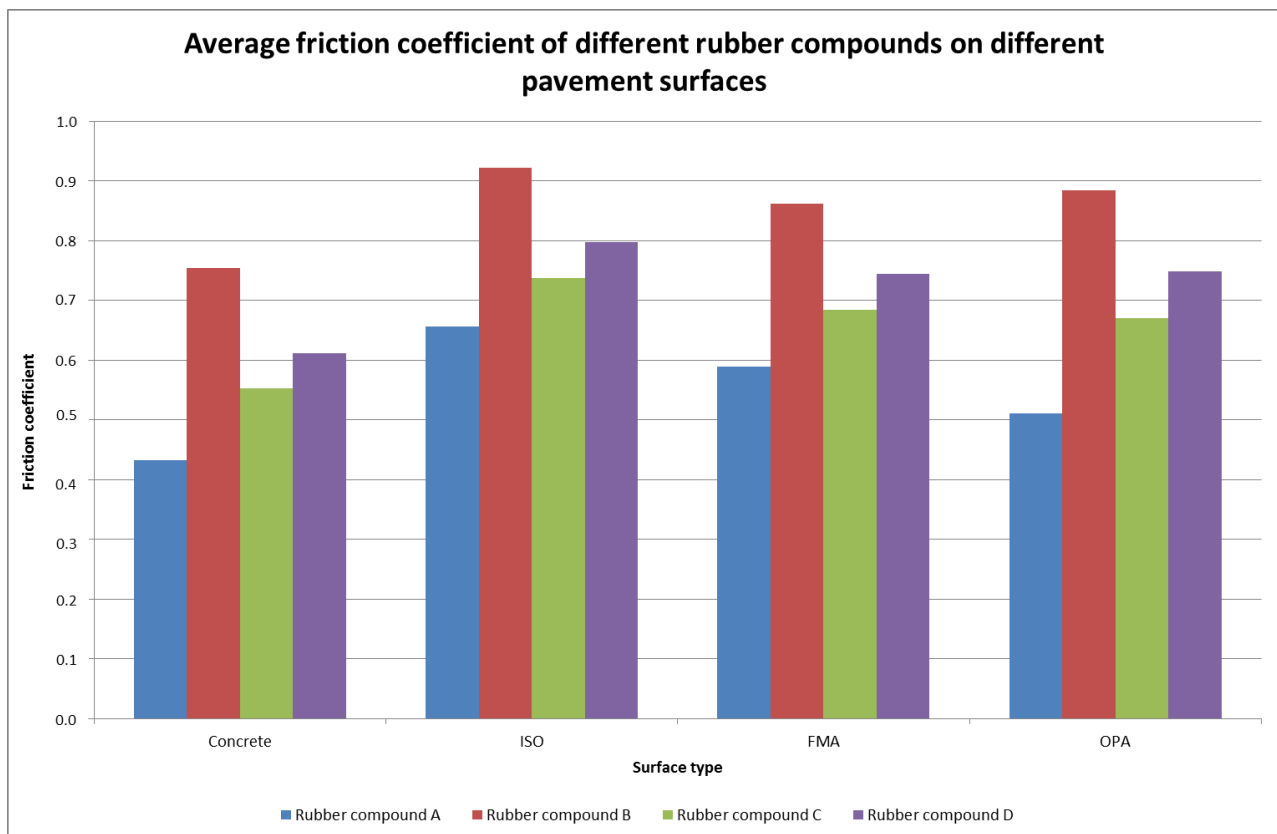

Figure 19: Test results of skid resistance of different rubber compounds on different surface layers.

### 6.4 Ravelling

When the adherence between bitumen and stone/mineral diminishes or the bitumen starts to fail, stone loss occurs on the road surface. As soon as a single stone is lost, the support for the adjacent stones also disappears. The process then soon accelerates. This is a particularly common form of damage in very porous types of asphalt in particular. The consequences of ravelling include less evenness, less skid resistance, less comfort and broken windshields for road users, and more noise for the environment.

Ravelling can also be tested in the SR-ITD [6]. The purpose of the test is to give an indication of the resistance to ravelling. The phenomenon is caused by shear forces, in transverse and longitudinal direction. These shear forces are caused by deformation of the tyre, torsion and braking. This observed behaviour can be simulated and measured in the SR-ITD on both unconditioned and conditioned (aged) specimens. The shear forces that introduce stone loss, are measured. The output of the test is the amount of stone loss versus number of load repetitions.

The characteristics of a successful ravelling test in the SR-ITD are:

- representative measurable vertical load (heavy traffic);
- many load repetitions in a short time simulates fatigue by shock loads in a short contact time of tyre and stone and no one-time overloading;
- continuously measuring shear resistance forces and conditions (such as temperature of rubber and asphalt surface);
- large continuous measuring length of about one meter during one rotation of the specimen;
- no unnecessary and unwanted edge damage of the specimen (separating unintended ravelling by edge damage and ravelling by actual load applied).

This test configuration is able to give a ranking of the resistance to ravelling of different asphalt mixtures as can be seen in Figure 20.[7]

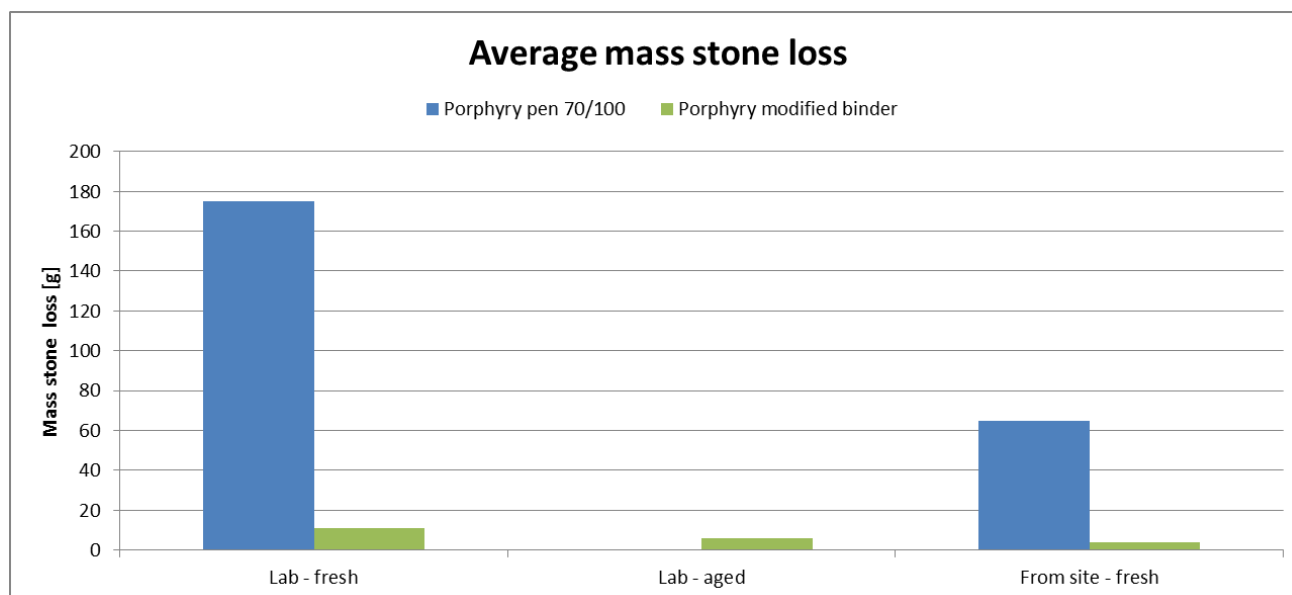

Figure 20: Typical SR-ITD results of average stone loss of different asphalt mixtures

## 7. CONCLUSIONS

The Skid Resistance & Smart Ravelling Interface Testing Device has been designed and built for the study of the influence and the interaction of the various phenomena occurring at the rubber pavement interface during driving and braking. This paper has given an overview of the 5 year development and current capabilities of this device. The patented laboratory testing machine enables various combinations of slip velocity and pressure to be applied with concurrent measurement of temperature in the interface regions. With this equipment it is also possible to study the ravelling resistance of a surfacing material (asphalt, cement concrete or a surface dressing). It was developed to study and evaluate materials in the laboratory on a smaller scale and much faster than in real practice. The materials to test can be the rubber on the tyres or the surface of the road: asphalt, concrete or other surface materials.

This innovative device is at the moment the only one (as far as the authors are aware), that can evaluate, at laboratory level, the friction due to the interaction between a rubber sample and an asphalt concrete surface for several speeds, pressure levels (car or truck) and temperatures.

## ACKNOWLEDGEMENT

The major part of the development of the SR-ITD was carried out in the context of the project: Enhanced Driver Safety due to Improved Skid Resistance (SKIDSAFE) financed by the European Union 7th Framework Program, Theme: Safety and Security by Design.

## References

- [1] Development of the Skid Resistance Interface Testing Device, R. Khedoe , Report 1.2, May 2011.
- [2] Modelling of Rubber Friction on Asphalt Surfaces using a Fractal Approach, Villani M.M., Scarpas, A. and Kane, M., Proceedings of the 5th International Conference on Bituminous Mixtures and Pavements, Thessaloniki, Greece, June 2011.
- [3] On the importance of rubber temperature in tire-rubber friction on stone surfaces, Villani M.M., Scarpas A., Khedoe R., de Bondt A., Spieard F., Kasbergen C., Artamendi I., ICTI conference, Pisa, April 2014.
- [4] On the importance of temperature for the evaluation of friction for AC mixes, Villani M.M., Scarpas A., Khedoe R., de Bondt A., Spieard F., Kasbergen C., Proceedings of the 90th Annual Transportation Research Board Meeting, January 2014.
- [5] On the Importance of the Rubber Characteristics on the Frictional Response of Asphalt Concrete Surfaces, .M. Villani, A. Scarpas, A. de Bondt, R. Khedoe, C. Kasbergen, Proceedings of the 91th Annual Transportation Research Board Meeting, January 2015.
- [6] Rafelingsproef met Skid Resistance & Smart Ravelling - Interface Testing Device, Test procedure 2625-167-09 CROW, December 2014 (in Dutch).
- [7] Rafelingsproeven in SR-ITD - Proefvak N346 – Provincie Gelderland, R. Khedoe, Report, July 2015 (in Dutch).